

Model 44 *Interface*

User Guide

Issue 2, September 2006

This User Guide is applicable for serial numbers:
M44-00151 and later

Copyright © 2006 by Studio Technologies, Inc., all rights reserved
www.studio-tech.com

This page intentionally left blank.

Introduction

The Model 44 is designed to work with 200-series announcer's console products from Studio Technologies. The unit serves as an interconnection "hub," providing power and signal routing for up to six announcer's consoles. The Model 44 is appropriate for in-studio as well as field broadcast applications. Of special note is its applicability for use in the live television sports industry. The compact, one-rack-space enclosure is constructed using heavy-gauge steel components.

For installation simplicity the Model 44 connects to the announcer's consoles using Ethernet-type twisted-pair cable assemblies. Each of the Model 44's six channels connects to its associated announcer's console using an RJ45 jack. Of the four pairs in the jack, two are intended for transmission of digital audio signals. A third pair can be used to carry digital or analog audio signals, as well as being used for special installation-specific applications. The fourth pair is used to carry 24 volt DC, 150 milliamperes nominal maximum, to the announcer's console. The power provided by each of the Model 44's six channels is individually over-current and short-circuit protected. This minimizes the chance that an error on one channel will impact the others.

A second set of six RJ45 jacks provides access to two pairs from the announcer's consoles' RJ45 jacks. These jacks are normally used to connect the digital audio input and output signals to the main broadcast system equipment, such as a digital matrix intercom system, an audio console, or a routing switcher. The Model 44 also provides a 25-pin D-subminiature connector that is used to provide access to a third cable pair from the announcer's consoles' RJ45 jacks.

The unit's mains power input can be in the range of 100 to 230 volts, 50/60 hertz. This "universal input" ensures correct operation virtually anywhere in the world. Two 24 volt nominal, 30 watt internal power supplies provide redundancy for critical broadcast applications. For special applications an external source of 24 volts DC can also be connected. This allows, for example, battery operation of the Model 44 and associated announcer's consoles. Three LED indicators, located on the unit's front panel, provide status indication of the two internal and one external power sources.

For special applications the Model 44 provides a nominal 24 volt, 70 milliamperes nominal maximum power source. This source could be useful when connecting devices such as "tally" status indicators.



Model 44 Front Panel



Model 44 Back Panel

Typical Application

A typical application would be to use the Model 44 Interface with up to six of the Model 212 Announcer's Consoles. The Model 212 features digital audio inputs and outputs with support for both AES3id (75 ohm unbalanced) and AES3 (110 ohm balanced) signals. To provide RJ45 interfacing capability, an EtherCon® interface connector kit, available from Studio Technologies, would be installed in one of the spare connector locations on the back of the Model 212. Using jumper wire assemblies three of the four cable pairs are assigned to Model 212 functions. One pair carries nominal 24 volt DC power from the Model 44 to the Model 212's circuitry. Two other pairs are used to carry AES3 (110 ohm balanced) digital audio signals to and from the Model 212. The fourth pair can remain unused, or be used to implement a special function such as a remote microphone on/off switch.

Installing and wiring the Model 44 in our typical application is very simple. Standard unshielded twisted-pair cable assemblies, ubiquitous to the computer industry, can be used to connect the Model 212 units to the RJ45 jacks on the back panel of the Model 44. Alternately, ruggedized cable assemblies can be fabricated using Neutrik® EtherCon connectors. A second set of six RJ45 jacks, also located on the Model 44's back panel, are used to link the digital audio input and output signals with other equipment. For example, to interface with the Riedel® Artist® intercom system would require only the use of standard Ethernet-type 4-pair cable assemblies. If the fourth pair of the interconnecting cables has been implemented with a Model 212 function, its signals are accessible using the 25-pin D-subminiature connector. The "D-sub" connector, located on the Model 44's back

panel, is also used for connecting to the auxiliary 24 volt DC output and the external 24 volt DC input. To complete the installation typically requires only the power cord to be connected to the designated source of AC mains power.

Installation

In this section you will be installing and interconnecting the Model 44. The one-rack-space unit will be mounted in an equipment rack. Connections to the announcer console units and associated equipment will be made using twelve RJ45 jacks. Installer-selected input, output, or control signals can be connected using pins on the female 25-pin D-subminiature connector. An external source of 24 volts DC power can also be connected using pins on the female 25-pin D-subminiature connector. The same female 25-pin "D-sub" is also used to access the auxiliary 24 volt DC output. AC mains power is connected by means of a detachable cord set that is compatible with the Model 44's 3-pin IEC 320 C14-type inlet connector.

System Components

The shipping carton contains the Model 44 Interface and associated user guide. Units destined for North America and Japan also include an AC mains cord. Your dealer or distributor should provide an AC mains cord for other destinations.

Locating the Model 44

In most cases the 100 meter cable length limit for AES3 digital audio signals will dictate the Model 44's mounting location. One cable will link the Model 44 to the announcer's console units. A second cable will connect the Model 44 to the associated digital audio equipment. Ensure that the

total length of the two cable segments doesn't exceed 100 meters.

Mounting the Model 44

Once the desired mounting location has been selected, the Model 44 will require one space (1.75 vertical inches) in a standard 19-inch equipment rack. Secure the unit into the equipment rack using two mounting screws per side.

Announcer's Console Connections

The Model 44 provides support for up to six announcer's consoles. In most cases these will be digital audio-compatible units such as the Model 212 from Studio Technologies. On the Model 44's back panel are six RJ45 (8-position modular) jacks, one for each announcer's console connection. The eight signal connections in the RJ45 jacks are organized as four pairs and use the Ethernet convention: pins 4 and 5 (pair 1), pins 1 and 2 (pair 2), pins 3 and 6 (pair 3), and pins 7 and 8 (pair 4). Pair 4 is used to provide power to the announcer's console: +24 volts DC on pin 7, common on pin 8. Pair 2 (pins 1 and 2) is intended to carry digital audio signals from the announcer's console to the connected equipment. Pair 3 (pins 3 and 6) is intended to carry digital audio signals from the connected equipment to the announcer's console.

Inside the Model 44 pairs 2 and 3 are routed directly to six additional RJ45 jacks. Pair 1 (pins 4 and 5) is intended for use in installer-selected applications. These include sending or receiving analog audio, digital audio, control, or "tally" signals. The connections from pair 1 (pins 4 and 5) on all six announcer's console RJ45 jacks are connected inside the Model 44 to pins on the female 25-pin D-subminiature connector.

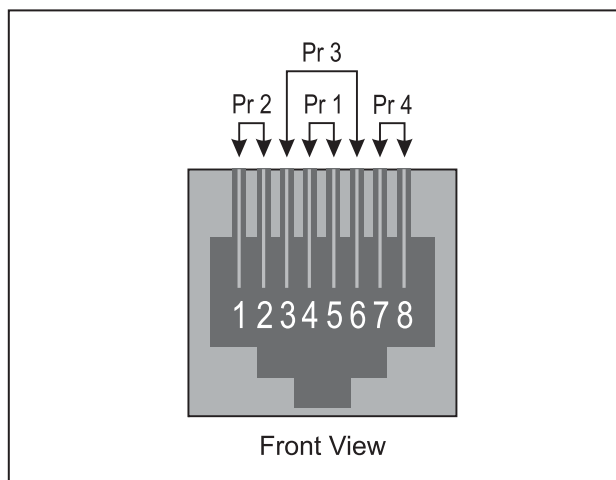

Figure 1. RJ45 Jack (8-Position Modular)

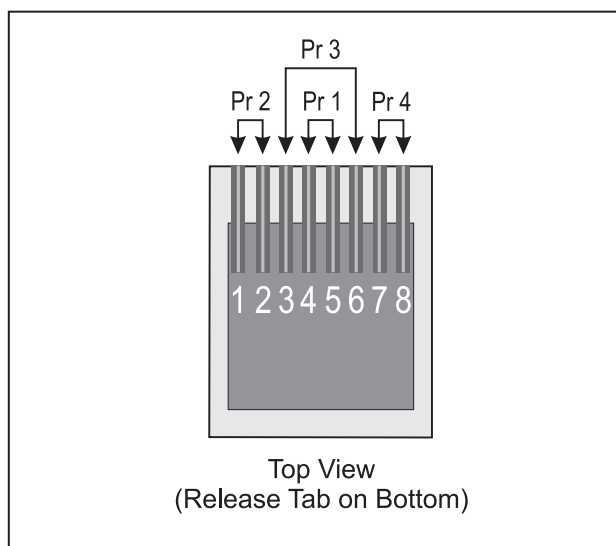

Figure 2. RJ45 Plug (8-Position Modular)

In fixed installations standard CAT5 or CAT5e Ethernet-style 4-pair cabling can be used to link the Model 44 with the announcer's consoles. The cables should be implemented with a straight-through "568A" or "568B" wiring scheme. For remote broadcast or sound reinforcement applications it may be desirable to use ruggedized "tactical" cables. In this case using protected RJ45 plugs, such as the Neutrik EtherCon, may be appropriate. An input/output (I/O) panel, separate from the jacks on the Model 44, should be created

as the interconnection point. Short “jumper” cables can be used to link the RJ45 jacks on the Model 44 with the connectors on the I/O panel. Using feed-through adapters (standard RJ45 to ruggedized RJ45) on the I/O panel, such as the Neutrik NE8FDP, make this type of installation simple.

System Connections

Inside the Model 44, pairs 2 and 3 (pins 1 and 2, 3 and 6) on the RJ45 jacks associated with the announcer’s consoles are connected directly to six additional RJ45 jacks. These jacks, located on the Model 44’s back panel, maintain a one-to-one connection scheme: pin 1 to pin 1, pin 2 to pin 2, pin 3 to pin 3, pin 6 to pin 6. These six RJ45 jacks, labeled System, are intended to connect to the audio equipment that will send and receive digital audio signals associated with the announcer’s consoles.

The required system interconnecting cables will depend on the type of equipment to be interfaced. In some cases standard Ethernet CAT5 or CAT5e “patch” cables may be all that is required. An example would be ports on a digital matrix intercom system from Riedel Communications. In other cases adapters going from RJ45 to 3-pin XLR-type may be appropriate.

Auxiliary Input/Output Connections

As previously mentioned, connections from pair 1 (pins 4 and 5) of the RJ45 jacks associated with the announcer’s consoles are directly connected to pins on a female 25-pin D-subminiature connector. This connector, located on the Model 44’s back panel, is provided for installer-selected applications. A cable harness is required with a male 25-pin D-sub plug on one end and the desired mating connectors on the other. This cable harness is not supplied by Studio

Technologies. (Note that in some locations the term “cable loom” may be used instead of “cable harness.”) Some of you might observe that the wiring scheme used by the D-sub complies with the now-ubiquitous one made familiar by TASCAM® with their DA-88® product. A wiring harness prepared for connection to the Model 44’s audio inputs is identical to a DA-88-style input harness. Please refer to Figure 3 for connection details. Note that unlike a DA-88-style harness, the Model 44’s D-sub connector’s hold-down screws use 4-40 threads. This complies with the original design standard for D-subminiature connectors which used English rather than metric thread pitch.

Connections	RJ45 Pin 4	RJ45 Pin 5	Shield
To/From Announcer’s Console 1	24	12	25
To/From Announcer’s Console 2	10	23	11
To/From Announcer’s Console 3	21	9	22
To/From Announcer’s Console 4	7	20	8
To/From Announcer’s Console 5	18	6	19
To/From Announcer’s Console 6	4	17	5

Notes: 1) Connector type on Model 44 is 25-pin D-subminiature female. Installer must provide plug (male). Connector uses 4-40 threaded inserts for locking with mating plug.
2) Wiring scheme follows TASCAM DA-88 convention. Standard DA-88-style wiring harnesses are directly compatible, with the exception of 4-40 screw threads being required.

Figure 3. Connections for Auxiliary Input/Outputs

Auxiliary DC Output

A source of 24 volts DC, 70 milliamperes nominal maximum, is provided for installer-selected applications. It may prove useful in specialized installations such as where broadcast remote control and tally signals are required. The DC output is accessible by way of pins on the female 25-pin

D-subminiature connection, located on the Model 44's back panel. Refer to Figure 4 for connection details.

External DC Input

For flexibility, provision has been made to allow an external source of 24 volts DC to power the Model 44. The source must be filtered and regulated, with a minimum current capability of 1.2 amperes. The external DC source is connected using two pins on the female 25-pin D-subminiature connector which is located on the Model 44's back panel. For connection details refer to Figure 4.

The external 24 volt DC source can be used instead of, or in addition to, the DC power created by the two internal power supplies. These three possible power sources are safely connected together (diode "OR'd") within the Model 44's circuitry.

Connections	+	-	No Connect
Aux 24 Vdc Output	15	3	16
External 24 Vdc Input	1	14	2

- Notes:** 1) Connector type on Model 44 is 25-pin D-subminiature female. Installer must provide plug (male). Connector uses 4-40 threaded inserts for locking with mating plug.
- 2) Wiring scheme follows TASCAM DA-88 convention. Standard DA-88-style wiring harnesses are directly compatible, with the exception of 4-40 screw threads being required.

Figure 4. Connections for Auxiliary 24 Volt DC Output and External 24 Volt DC Input

AC Mains Power

The Model 44's two internal power supplies operate directly from AC mains power of 100 to 230 volts, 50/60 hertz. The power supplies are "universal input" type with no switches to set or jumpers to install to

match a location's nominal AC mains voltage. For locations that have an AC mains power source of 240 volts, contact Studio Technologies for confirmation that a direct connection can be made.

The Model 44 uses a 3-pin IEC 320 C14-type inlet connector to mate with a detachable mains cord set. For units shipped to North America and Japan a cord is supplied that has a North-American (NEMA 15L) standard plug on one end and an IEC 320 C13-type connector on the other. Units bound for other destinations require that the appropriate cord set be obtained. The wire colors in the mains cord must conform to the internationally recognized color code and should be terminated accordingly:

Connection	Wire Color
Neutral (N)	Light Blue
Line (L)	Brown
Earth/Ground (E)	Green/Yellow

Safety Warning: The Model 44 does not contain an AC mains disconnect switch. As such, the AC mains cord plug serves as the disconnection device. Safety considerations require that the plug and associated inlet be easily accessible to allow rapid disconnection of AC mains power should it prove necessary.

As soon as AC mains power is applied the Model 44 will begin operation. An LED status indicator is associated with each of the two internal power supplies. Both should light as soon as mains power is applied.

Operation

The Model 44 is designed for continuous operation with no adjustment or maintenance required. Three red-colored LEDs,

visible from the front panel, provide a status indication of the active power source(s). Two of the LEDs light whenever their respective internal power supplies are functioning. With AC mains power connected both should be lit. If an external source of 24 volts DC is connected it's LED should also be lit.

Troubleshooting

If you're having trouble getting the Model 44 up and running, this section may help. If you haven't read the previous sections of this guide, you should do so before proceeding.

The first thing to confirm, no matter what symptoms are present, is that the desired source of incoming power has been correctly connected. If a source of AC mains power is being provided to the Model 44, the two LEDs associated with the internal power supplies should be lit. If neither is lit check the AC mains source to ensure that it is active and that the power cord is securely mated with the power entry connector. If only one of these LEDs is lit, a defective power supply is most likely the cause. While temporary operation with one only functioning internal power supply is acceptable, long-term reliability will be compromised. In this case the Model 44 needs to be returned to the factory for repair. If an external source of 24 volts DC has been connected, its associated LED indicator, located on the front panel, should be lit. If it is not, check the power source and associated wiring.

Correct operation of the connected announcer's consoles is primarily dependent on accurate interconnect wiring. If the announcer's consoles do not "power up" then the wiring associated with pair 4 (pins 7 and 8) of the interconnecting cable must

be checked. Straight-through wiring is required. The connection is polarity sensitive, with positive on pin 7 and common on pin 8.

Specifications

Applications: designed to work with up to six Model 200-series announcer's consoles from Studio Technologies

Announcer's Console Power Sources: 6
24 volts DC nominal (26 volts actual with internal power supplies active), 150 milliamperes nominal maximum; over-current and short-circuit protected

Interconnection Cable Limit: designed to correctly support 200-series announcer's consoles located up to 100 meters from Model 44 when using standard computer-type unshielded twisted-pair cabling

Auxiliary 24 Volt DC Output: 24 volts DC nominal (26 volts actual with internal power supplies active), 70 milliamperes nominal maximum; over-current and short circuit protected

External 24 Volt DC Input: 24 volts nominal (24-28 volts acceptable), 1.2 amperes minimum

Connectors:

Announcer's Console: 6, RJ45 (8-position modular)

System: 6, RJ45 (8-position modular)

Aux In/Out, Aux 24 Volt DC Output, External 24 Volt DC Input: female 25-pin D-subminiature, 4-40 threads

AC Mains: 3-blade, IEC 320 C14-compatible (mates with IEC 320 C13)

AC Mains Requirement: 100-230 volts, 50/60 Hz, 0.8 A maximum @ 100 volts, 0.5 A maximum @ 230 volts

Dimensions (Overall):

19.00 inches wide (48.3 cm)

1.72 inches high (4.4 cm)

9.58 inches deep (24.3 cm)

Mounting: one space in a standard 19-inch rack

Weight: 6.3 pounds (2.9 kg)

Specifications and information contained in this User Guide subject to change without notice.

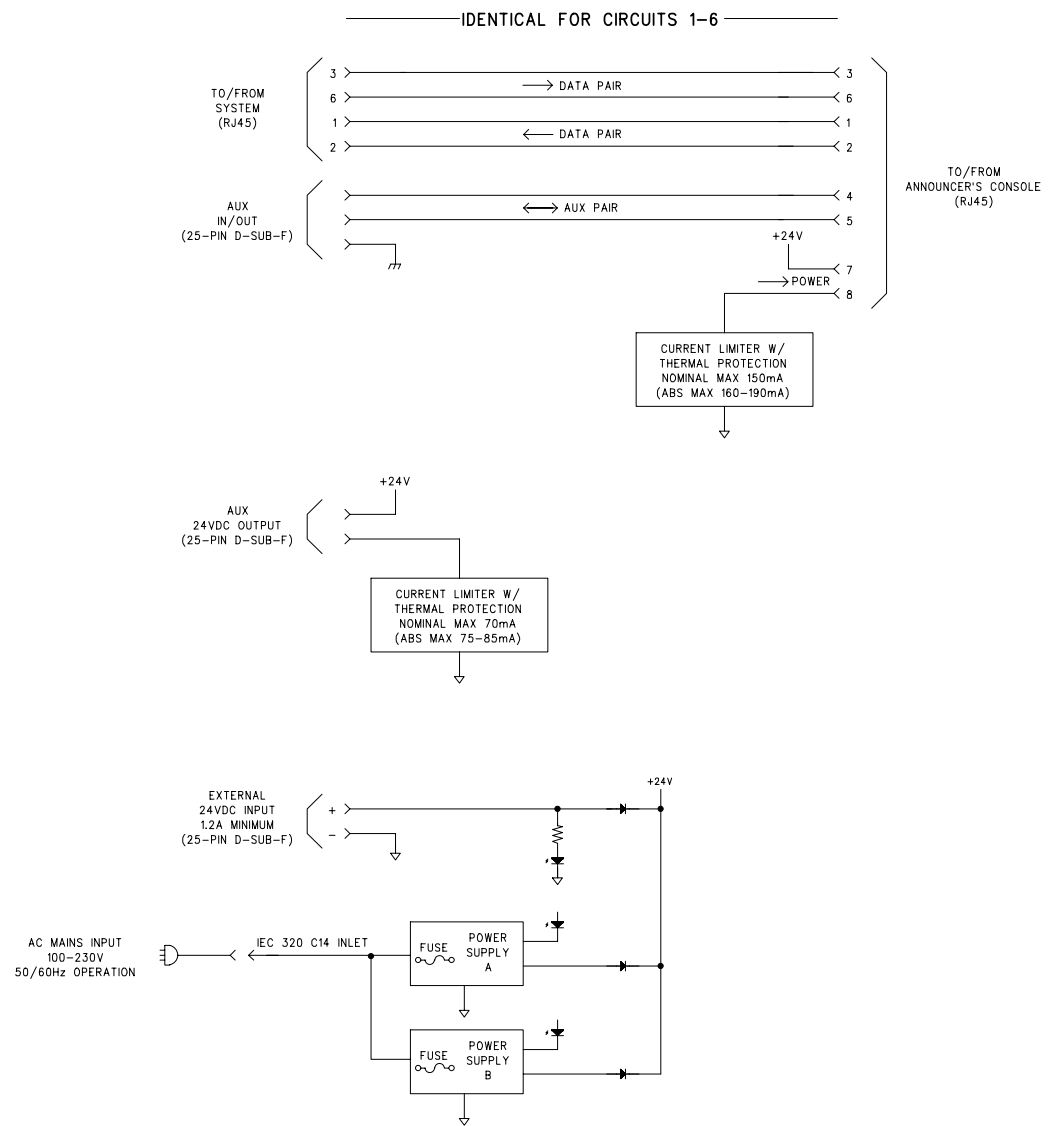

M44BD_B

STUDIO TECHNOLOGIES, INC.		
MODEL 44 INTERFACE BLOCK DIAGRAM		
DRAWING NO. 31200	DATE 09/13/06	PAGE 01 OF 01